

MAAI manual Chrono & 4B

Manual hands laying machine for chrono counter

The MAAI manual Chrono and MAAI manual Chrono 4 Spindles" are high-precision machines for setting central and off-center hands.

Datasheet, 31.05.2023, V1.1

 Engineered and made in Switzerland

Machine functions

- Used to fit counter hands (MAAI Chrono).
- Used to fit counter and central hands (MAAI Chrono 4B).
- Used to fit counter hands simultaneously.
- Practical, reliable, efficient and compact space requirements.
- Hands perfectly and precisely aligned on their indexes.
- Can adapt to all hand sizes.
- Rapid adjustment of hand driving height.
- Rapid caliber changeover thanks to the tool bar device (MAAI Chrono 4B).

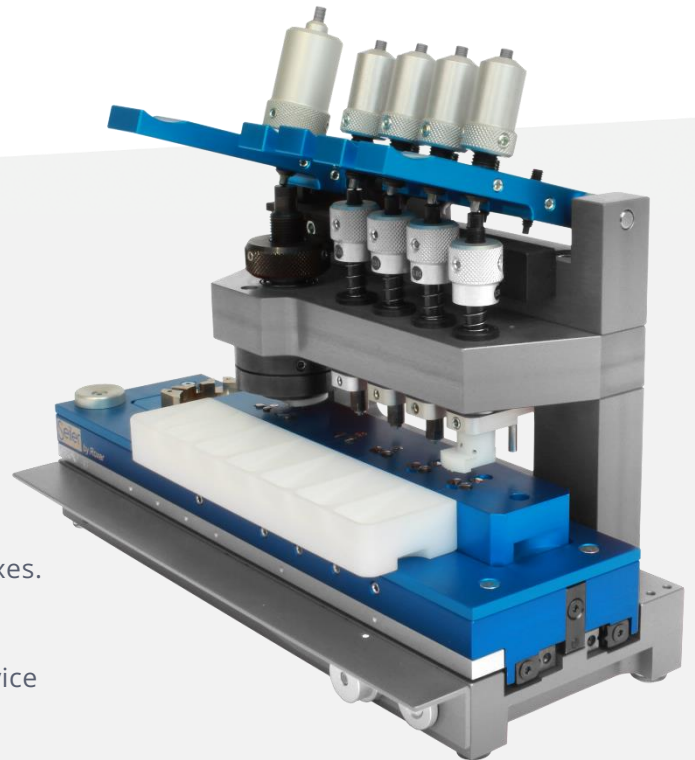

MAAI manual Chrono 4B

MAAI manual Chrono

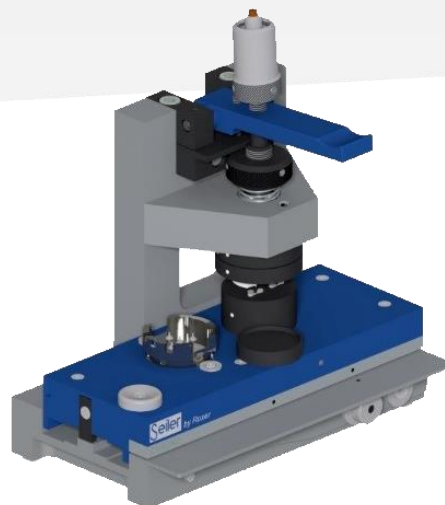

Technical specifications

	<i>MAAI manual Chrono</i>	<i>MAAI manual Chrono 4B</i>
Chrono spindle force limiter :	1 to 18 kg	1 to 18 kg
Standard spindle force limiter :	N/A	1 to 6 kg
Hour and minute hand pick-up :	Mechanical	Mechanical
Seconds hand pick-up*:	Mechanical	Mechanical
Counter hand pick-up*:	Vacuum	Vacuum
Weight :	2,9 kg	4,6 kg
Dimensions (l/d/h) :	175 x 109 x 205 mm	255 x 109 x 205 mm

*Tools : see MAAI Tools data sheet

*Seconds hand vacuum pick-up on request

*Counter hand mechanical pick-up on request

Available options (with DCF PAD)

Datomat for date change

- Absolute precision, obtained through the motor encoder
- Easy motor position setting and out-of-round correction
- "Teach In" setting assistance function
- Adjustable sensitivity, speed and rotation direction (40 to 280 rpm)

Driving force control

- Min. and max. driving force limit adjustable for each hand
- Data can be saved and retrieved in Excel
- Force display during driving

Backlighting

- Allows better visibility when picking up and placing hands.